

## Specifications:

Model #: LG-HA-1100

Load Rating: 800kg Max\*

\*Loads over 600kg must be a static load.

Suits: LG-EH-0100, LG-EH-0500 & LG-EH-0800 electric hoists

Net Weight: 6kg

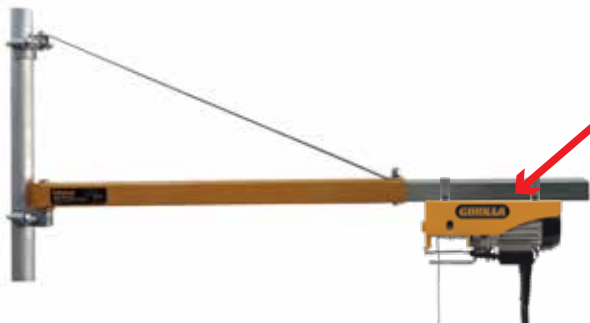
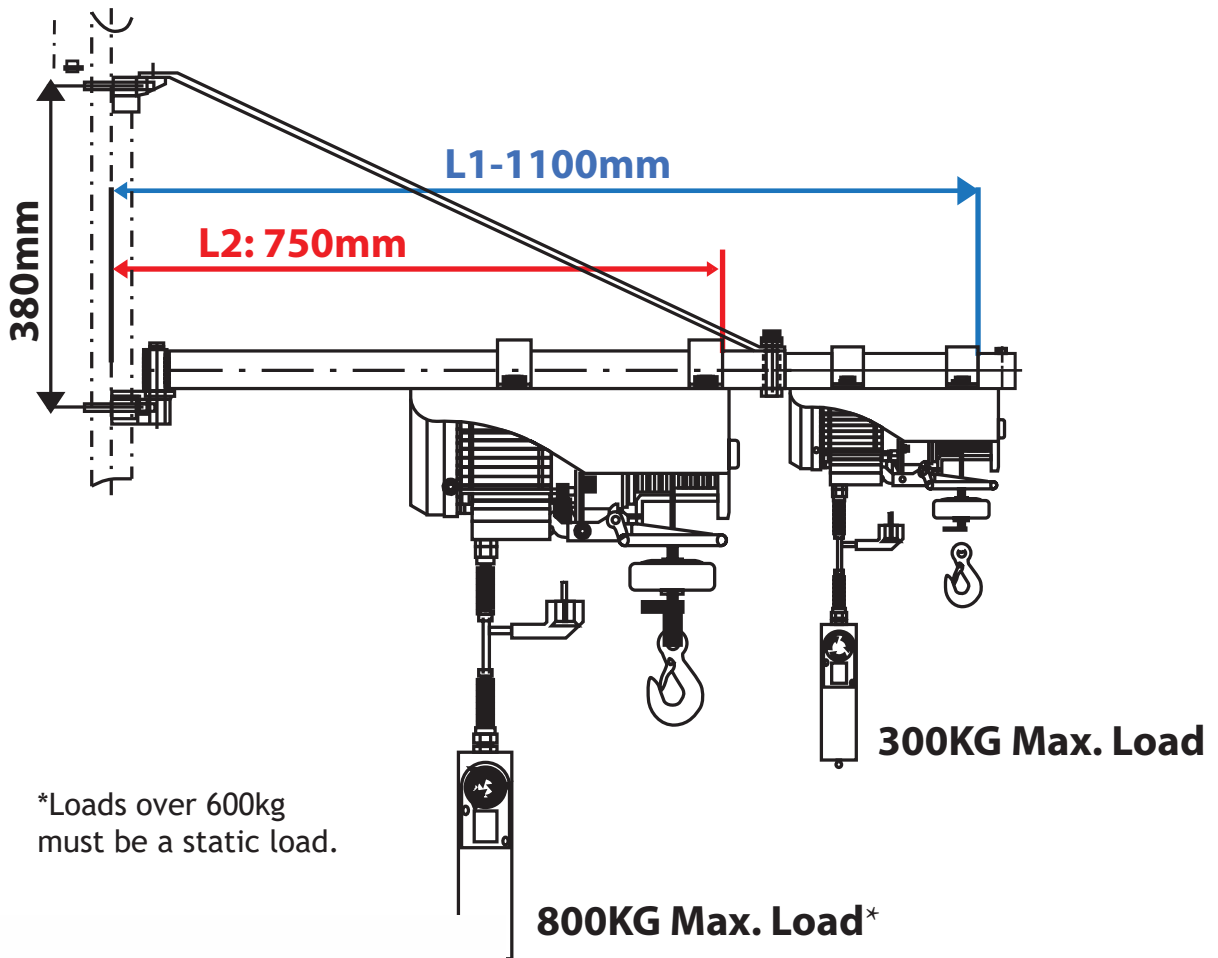

**Note:** Gorilla LG-EH-0100 (100kg electric hoist) can only be installed onto the silver extension piece as shown in Fig 1. It will not fit onto the shorter yellow section of hoist arm.